

2004 Queen of the Bay Sailing Instructions



1. RULES

The race will be governed by the Racing Rules of Sailing, 2001-2004, the prescriptions of the United States Sailing Association, class rules, the rules and regulations of the Queen of the Bay, and by these Sailing Instructions.

2. DISCLAIMER OF LIABILITY

Competitors participate in the regatta entirely at their own risk. See Rule 4, Decision to Race.

The Bellport Bay Yacht Club, Officers, and Members will not accept any liability for material damage or personal injury or death sustained in conjunction with or prior to, during, or after the regatta.

3. ENTRIES

- 3.1 Eligible competitors shall be entered by completing registration at Bellport Bay Yacht Club by 1p.m. Sunday, September 5th, 2004. Entry shall be denied to participants who do not comply with the GSBYRA Queen of the Bay regulations published in the 2004 GSBYRA Yearbook.
- 3.2 To be eligible to race, the helmsman shall be a member of a GSYBRA member club.
- 3.3 To be eligible to race, a yacht's owner shall be a member of a GSYBRA member club, and the yacht shall have a valid GSYBRA rating, with a GSBYRA DPN rating 120 or lower. If the yacht's rating is not noted in the 2004 GSYBRA Yearbook, a handicap questionnaire shall have been submitted to the GSBYRA Handicap Chairman at least one month before the race.
- 3.4 To be eligible for a corrected time award, one design yachts shall strictly meet their class rules regarding sail area, weight, measurement, gear and crew. All other yachts shall strictly conform to measurements and other data submitted to the GSYBRA Handicap Committee regarding weight, gear and crew on which her rating was calculated.
- 3.5 Eligible competitor's yachts shall display class insignias and sail numbers
- 3.6 Yachts and helmsmen not complying with these regulations shall be subject to protest by other competitors, or the Queen of the Bay Race Committee. An authorized GSBYRA representative shall determine whether or not the yacht and helmsman are qualified under these rules.

4. NOTICE TO COMPETITORS & CHANGES TO THE SAILING INSTRUCTIONS

Notices will be posted on the official bulletin board located in the club on the day it will take effect, 1 hr before the race.

5. SCHEDULE OF RACE: 14:00 hrs Sunday, September 5th, 2004, at Bellport Bay Yacht Club.

6. COURSES

The diagrams below show the courses, the order in which marks are to be rounded or passed, and the side on which each mark is to be left. Courses will be designated by a letter A, or B or C.

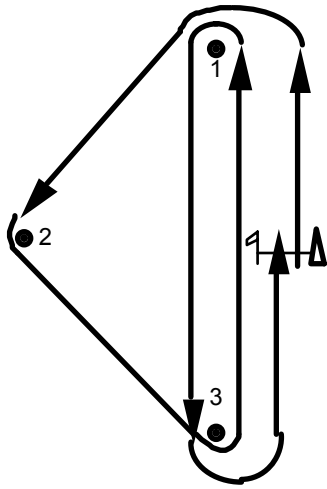

Course A
Start-1-2-3-1-3-finish

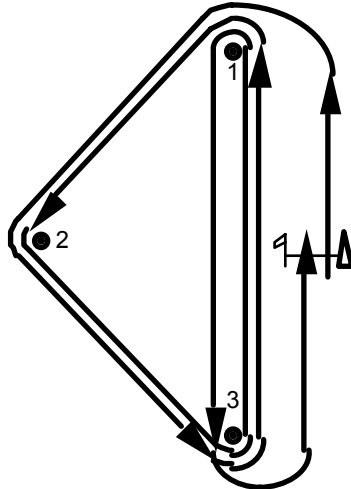

Course B
Start-1-2-3-1-2-3-1-3-finish

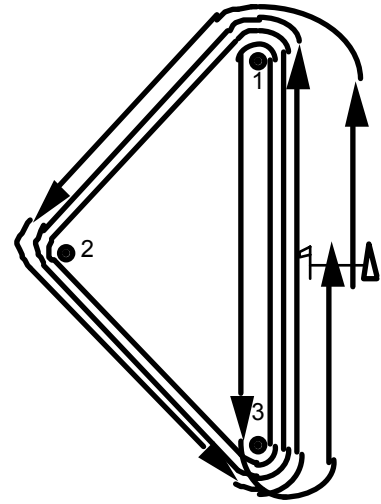

Course C
Start-1-2-3-1-2-3-1-2-3-1-3-finish

7. **MARKS will be large orange inflatable cylinders.**

8. VISUAL SIGNALS AFLOAT

- 8.1 Code flag "AP" (RED AND WHITE VERTICAL STRIPES) with 2 sound signals means POSTPONEMENT. One sound signal, signals the lowering of "AP", and the warning signal will be made 1 minute after "AP" is lowered.
- 8.2 Code flag "N" (BLUE AND WHITE CHECKS) with 3 sound signals means ABANDON RACE. One sound signals, signals the lowering of "N", and the warning signal will be made 1 minute after "N" is lowered.
- 8.3 Code flag "N" over "H" (BLUE AND WHITE CHECKS OVER RED AND WHITE VERTICAL BAND) with 3 sound signals means ABANDON RACE AND HEAD FOR SHORE. Check official bulletin board for rescheduling.
- 8.4 Code flag "Y" (RED AND YELLOW DIAGONAL STRIPES) means all competitors shall wear **LIFE JACKETS** while racing (rule 27.1).

9. START/FINISH

- 9.1 The start and finish line will be between a staff displaying an orange flag on the race committee boat at the starboard end and the course side of the orange inflatable sphere at the port end starting mark.
- 9.2 The race will be started in accordance with racing Rule 26, with all yachts starting together.

14:00	Code flag #1 raised	Warning
14:01	Code flag "P" raised	Preparatory
14:04	Code Flag "P" lowered	One Minute
14:05	Code flag #1 lowered	Start

10. RECALLS

- 10.1 Code flag "X" (BLUE CROSS ON WHITE FIELD) with 1 sound signal means INDIVIDUAL RECALL for one or more yachts. The Committee will endeavor to notify each yacht recalled by hailing its number, but it is the responsibility of each yacht to make a proper start. "X" will be lowered when all yachts are clear.
- 10.2. Code flag "First Substitute (BLUE AND YELLOW PENNANT) with 2 sound signals means GENERAL RECALL. "First Substitute" will be lowered with one sound signal, 1 minute before the new preparatory signal is made.

11. SHORTEN COURSE

Code flag "S" (BLUE SQUARE ON WHITE FIELD) with 2 sound signals means SHORTEN COURSE. The Committee may shorten course after the start by finishing the race at any rounding mark. The finish will be between the mark and a boat displaying the "S" flag.

12. WITHDRAWAL

A yacht shall make every effort to notify the Race Committee as soon as possible.

13. TIME LIMIT is 3 and 1/2 hours for all yachts to finish.

14. 720 TURNS PENALTY will apply.

15. PROTEST

15.1 Protest shall be written on forms available from the race committee and lodged there within Protest Time which will begin when the race committee boat docks and end 1 hour later.

15.2 Protest notices will be posted within 30 minutes of the protest time limit to inform competitors where and when there is a hearing in which they are parties to a protest or named as witnesses.

16. SCORING is based on the following:

16.1 The first eligible conventional yacht to finish with the lowest elapsed time will receive the **Growthage Bowl**.

16.2 The first eligible yacht, regardless of hull type or rig, to finish with the lowest elapsed time will receive the **Everitt Trophy**.

16.3 The first eligible conventional yacht to finish with the lowest corrected time based on current GSBYRA Portsmouth numbers will receive the **Patchogue Advance Trophy**.

16.4 The first eligible multi-hull yacht to finish with the lowest corrected time based on current GSBYRA Portsmouth numbers will receive the **Gallina Trophy**.

16.5 The official GSBYRA season scorer verifies eligibility of all competitors.

17. PRIZES

17.1 **Prizes will be awarded at the 2004 GSBYRA Fall Awards Dinner, Friday October 15, at Bay Shore Yacht Club.**

17.2 Winners receive a keeper trophy and have their names engraved on the four Perpetual Trophies, which are on display at the Long Island Maritime Museum during the year.